



NYX-7

Night Vision Goggles



OPERATION AND MAINTENANCE MANUAL

Important Export Restrictions! Commodities, products, technologies and services of this manual are controlled by the U.S. Department of State Office of Defense Trade Controls, in accordance with International Traffic in Arms (ITAR), Title 22, Code of Federal Regulations Part 120-130 and/ or by the Export Administration Regulations (EAR) of U.S. Department of Commerce. At any time when a license or a written approval of the U.S. Government is applicable to it, it is illegal and strictly forbidden to export, intend to export, transfer in any other manner whatsoever, sell any hardware or technical data, provide any associated service to any non-U.S. resident, beyond or within the United States territory, until the valid license or written approval has been issued by the Departments of the U.S. Government having jurisdiction. Additionally U.S. law prohibits the sale, transfer, or export of items to certain restricted parties, destinations, and embargoed countries, as identified on lists maintained by the U.S. Department of State, the U.S. Department of Commerce, and the U.S. Department of Treasury. It is the responsibility of the Customer to be aware of these lists. The sale, transfer, transportation, or shipment outside of the U.S. of any product prohibited or restricted for export without complying with U.S. export control laws and regulations, including proper export licensing, documentation or authorization, is unlawful and may result in civil and/ or criminal penalties and/ or constitute a federal crime. Diversion contrary to U.S. law is strictly prohibited.



SAFETY SUMMARY

Before operating this product, you must carefully read and study this Operation and Maintenance Manual.

The Nyx-7 is a precision electron-optical instrument, and requires careful handling. To avoid damage to the equipment or physical harm to the user when operating the Nyx-7, follow all WARNINGS, CAUTIONS and NOTES.

Below you will find definitions of the following alerts that appear throughout this Manual:

WARNING — Identifies a clear danger to the person operating the equipment.

CAUTION – Identifies risk of damage to the equipment.

NOTE – Serves to highlight essential procedures, conditions, and statements, or convey important instructional data to the user.

The information provided in this manual is for familiarization purposes only; the contents may undergo further changes with no commitment by Armasight® to notify customers of any updates.

Armasight® assumes no responsibility for any misprints or other errors that this manual may contain.

©2012 by Armasight. All rights reserved.

WARNINGS:

- **This product contains natural rubber latex which may cause allergic reactions!** The FDA has reported an increase in the number of deaths that are associated with an apparent sensitivity to natural latex proteins. If you are allergic to latex, it is a good idea to learn which products contain it and strictly avoid exposure to those products.
- The light from the unit infrared (IR) illuminator is invisible to the unaided eye when used in total darkness. **However, the light can be detected by other Night Vision Devices (NVD).**
- To reduce the risk of detection by another NVD, avoid prolonged activation of the IR illuminator.
- The IR light is more detectable by an NVD when used in smoke, fog and rain. Avoid prolonged activation of the unit IR illuminator in these conditions.
- The intensifier's phosphor screen contains toxic materials. Please note the following:
 - If the intensifier tube breaks, be **extremely careful** to avoid inhaling the phosphor screen material. DO NOT allow the material to come in contact with your mouth, eyes, or any open wounds on the skin.
 - If the phosphor screen material comes in contact with your skin, wash it off immediately with soap and water.
 - If you inhale or swallow any phosphor screen material, drink a lot of water, induce vomiting, and **seek medical attention as soon as possible.**

CAUTION:

- The Nyx-7 is a precision electron-optical instrument, and must be handled carefully at all times to prevent damage to the device and danger to the user.
- To protect the intensifier tube, **do not remove** the lens cap of the Nyx-7 when the unit is being operated in daylight conditions, or when the device is not in use.
- Use of the Nyx-7 in brightly lit conditions may damage the unit's intensifier tube.
- Bright light sources such as firelight, headlights, searchlights, etc. can damage the Nyx-7. Avoid exposing the unit to these types of light sources.
- DO NOT attempt to force the controls past their stopping points, as this may cause damage to the mechanisms.
- Before replacing the intensifier tube, confirm that it is no longer covered by warranty.
- Thoroughly clean and dry each component of the Nyx-7 before placing them in the storage case.

NOTES:

- The equipment requires some ambient light (moonlight, starlight, etc.) to operate.
- Performance of the device in nighttime conditions depends on the level of ambient light in the environment. Please remember the following:
 - The level of ambient light is reduced by the presence of clouds, shade, or objects that block natural light (trees, buildings, etc.).
 - The equipment is less effective when operated in shadows and other darkened areas.
 - The equipment is less effective when operated in rain, fog, sleet, snow, dust or smoke.
 - The equipment will not "see" through dense smoke.
- The IR illuminator is intended for increased illumination, as needed, when viewing at a close distance of up to 3m.
- For the purpose of returning defective components, retain all packaging materials.

LIST OF CONTENTS

TITLE	PAGE
Safety Summary	2
List of Contents	4
List of Figures	5
List of Tables	6
How to Use This Manual	6
1. INTRODUCTION	7
1.1 General Information	7
1.1.1 Type of Manual	7
1.1.2 Model Number and Equipment Name	7
1.1.3 Purpose of Equipment	7
1.1.4 Reporting Equipment Improvement Recommendations	7
1.2 Warranty Information and Registration	8
1.2.1 Warranty Information	8
1.2.2 Limitation of Liability	8
1.2.3 Product Warranty Registration	8
1.2.4 Obtaining Warranty Service	9
1.3 List of Abbreviations	10
2. DESCRIPTION AND DATA	11
2.1 System Description	11
2.2 Specifications	12
2.3 Standard Components	14
2.4 Optional Equipment	14
2.5 Key Features	16
3. OPERATING INSTRUCTIONS	17
3.1. Installation and Mounting	17
3.1.1 Battery Installation	17
3.1.2 Mounting the Nyx-7 to a Goggle Kit	18
3.1.3 Mounting the Nyx-7 to a Helmet	19
3.1.4 Mounting Accessory Lenses to the Nyx-7	19
3.1.5 Mounting an IR Illuminator to the Nyx-7	20
3.2 Controls and Indicators	21
3.3 Operating Procedures	22
3.3.1 Operating Procedures	22
3.3.2 IR Illuminator Operations	22
3.3.3 Nyx-7 Shut-Down	22
3.4 Storage	23
4. PREVENTIVE MAINTENANCE AND TROUBLESHOOTING	24
4.1 Preventive Maintenance Checks and Services (PMCS)	24
4.2 Troubleshooting	25
4.3 Identification of Operational Defects	29
4.3.1 Operational Defects	29
4.3.2 Cosmetic Blemishes	30

4.4 Maintenance	32
4.4.1 General	32
4.4.2 Cleaning Procedures	32
4.4.3 Battery Removal and Replacement	32
4.4.4 Goggle Kit Maintenance	32
4.5 Service/ Packing and Unpacking	34
APPENDIX	35
A. Nyx-7 List of Spare Parts	35
B. Product Warranty Registration Card	36
Alphabetical Index	35

LIST OF FIGURES

FIGURE	TITLE	PAGE
2-1	Nyx-7 Night Vision Goggles	12
2-2	Nyx-7 Standard Components	14
3-1	Battery Installation	17
3-2	Mounting the Nyx-7 to a Goggle Kit	18
3-3	Mounting the Nyx-7 to a Helmet	19
3-4	Mounting a 5X Lens to the Nyx-7	19
3-5	Mounting an IR Illuminator to the Nyx-7	20
3-6	Nyx-7 Controls	21
4-1	Shading	27
4-2	Edge Glow	27
4-3	Emission Points and Bright Spots	28
4-4	Fixed-Pattern Noise	28
4-5	Chicken Wire	28
4-6	Browpad Replacement	30
4-7	Chin Strap Reinstallation	30
4-8	Chin Cup Replacement	30
A-1	Nyx-7 Spare Parts	32

LIST OF TABLES

TABLE	TITLE	PAGE
2-1	Nyx-7 System Description	12
2-2	Mechanical Data	12
2-3	Electrical Data	13
2-4	Optical Data	13
2-5	Environmental Data	14
2-6	IR850 Specifications	14
2-7	Nyx-7 Standard Components	14

2-8	Nyx-7 Optional Equipment	15
3-1	Nyx-7 Controls and Indicators	21
4-1	Preventive Maintenance Checks and Services	24
4-2	Operator Troubleshooting	26
A-1	Nyx-7 List of Spare Parts	33

HOW TO USE THIS MANUAL

USAGE

You must familiarize yourself with the entire manual before operating the equipment. Before performing any kind of maintenance on your device, read the section on maintenance in its entirety. Follow all WARNINGS, CAUTIONS, and NOTES.

MANUAL OVERVIEW

This manual contains sections on Operating and Maintaining the Nyx-7 Night Vision Unit.

The list of Spare Parts can be found in Appendix A.

The Product Warranty Registration Card can be found in Appendix B.

INTRODUCTION

1.1 GENERAL INFORMATION

1.1.1 TYPE OF MANUAL

Operation and Maintenance (including a List of Spare Parts).

1.1.2 MODEL NUMBER AND EQUIPMENT NAME

This Manual accompanies the Nyx-7 Night Vision Goggles.

Throughout this manual, the Nyx-7 will be referred to as the goggles, the device, the equipment, or the Nyx-7.

1.1.3 PURPOSE OF EQUIPMENT

To provide the operator with the ability to observe scenes at night, under moonlight and starlight conditions.

The Nyx-7 can be used as a handheld, head-mounted or helmet-mounted device. When mounted to the head or a helmet, the user will be able to easily operate the device while walking, performing short-range surveillance, reading maps, performing vehicle maintenance, or administering first aid.

1.1.4 REPORTING EQUIPMENT IMPROVEMENT RECOMMENDATIONS

Armasight encourages user recommendations for improvements to the device.

Mail your comments to:

Armasight Inc.
815 Dubuque Avenue
South San Francisco, CA 94080
USA.

Or, you can send an email to info@armasight.com.

1.2 WARRANTY INFORMATION AND REGISTRATION

1.2.1 WARRANTY INFORMATION

This product is guaranteed to be free from manufacturing defects in material and workmanship under normal use for a period of two (2) years from the date of purchase. In the event that a defect covered by the below warranty occurs during the applicable period stated above, Armasight, at its discretion, will either repair or replace the product; such action on the part of Armasight shall be the full extent of Armasight's liability, and the Customer's sole and exclusive reparation. This warranty does not cover a product if it has (a) been used in ways other than its normal and customary manner; (b) subjected to misuse; (c) subjected to alterations, modifications or repairs by the Customer or by any party other than Armasight without prior written consent of Armasight; (d) special order or "close-out" merchandise or merchandise sold "as-is" by either Armasight or the Armasight dealer; or (e) merchandise that has been discontinued by the manufacturer and either parts or replacement units are not available due to reasons beyond the control of Armasight. Armasight shall not be responsible for any defects or damage that in Armasight's view are a result from the mishandling, abuse, misuse, improper storage or improper operation of the device, including use in conjunction with equipment that is electrically or mechanically incompatible with, or of inferior quality to, the product, as well as failure to maintain the environmental conditions specified by the manufacturer. CUSTOMER IS HEREBY NOTIFIED THAT OPERATION OF THE EQUIPMENT DURING DAYLIGHT HOURS OR UNDER ANY EXCESSIVE LIGHT CONDITIONS MAY PERMANENTLY DAMAGE THE INTERNAL COMPONENTS OF THE UNIT AND SAID DAMAGE WILL NOT BE COVERED UNDER THIS WARRANTY. This warranty is extended only to the original purchaser. Any breach of this warranty shall be enforced unless the customer notifies Armasight at the address noted below within the applicable warranty period.

The customer understands and agrees that except for the foregoing warranty, no other warranties written or oral, statutory, expressed or implied, including any implied warranty of merchantability or fitness for a particular purpose, shall apply to the product. All such implied warranties are hereby and expressly disclaimed.

1.2.2 LIMITATION OF LIABILITY

Armasight will not be liable for any claims, actions, suits, proceedings, costs, expenses, damages or liabilities arising out of the use of this product. Operation and use of the product are the sole responsibility of the Customer. Armasight's sole undertaking is limited to providing the products and services outlined herein in accordance with the terms and conditions of this Agreement. The provision of products sold and services performed by Armasight to the Customer shall not be interpreted, construed, or regarded, either expressly or implied, as being for the benefit of or creating any obligation toward any third party of legal entity outside Armasight and the Customer; Armasight's obligations under this Agreement extend solely to the Customer. Armasight's liability hereunder for damages, regardless of the form or action, shall not exceed the fees or other charges paid to Armasight by the customer or customer's dealer. Armasight shall not, in any event, be liable for special, indirect, incidental, or consequential damages, including, but not limited to, lost income, lost revenue, or lost profit, whether such damages were foreseeable or not at the time of purchase, and whether or not such damages arise out of a breach of warranty, a breach of agreement, negligence, strict liability or any other theory of liability.

1.2.3 PRODUCT WARRANTY REGISTRATION

In order to validate the warranty on your product, Armasight must receive a completed Product Warranty Registration Card for each unit, or the Customer can complete a warranty registration on our website, at www.armsight.com. Please complete the included form (Appendix C) and immediately mail it to our Service Center:

Armasight Inc.
815 Dubuque Avenue
South San Francisco
CA 94080
United States of America.

1.2.4 OBTAINING WARRANTY SERVICE

To obtain warranty service on your unit, the End-user (Customer) must notify the Armasight service department via email. Send any requests to service@armasight.com to receive a Return Merchandise Authorization number (RMA). When returning any device, please take in the product to your retailer, or send the product, postage paid and with a copy of your sales receipt, to Armasight Corporation's service center at the address listed above. All merchandise must be fully insured with the correct postage; Armasight will not be responsible for improper postage or merchandise that becomes lost or damaged during shipment. When sending product back, please clearly write the RMA# on the outside of the shipping box. Please include a letter that indicates your RMA#, the Customer's Name, a Return Address, reason for the return, Contact information (valid telephone numbers and/ or an e-mail address), and proof of purchase that will help us to establish the valid start date of the warranty. Product merchandise returns that do not have an RMA# listed may be refused, or a significant delay in processing may occur. Estimated Warranty service time is 10-20 business days. The End-user/ Customer is responsible for postage to Armasight for warranty service. Armasight will cover return postage/ shipping after warranty repair to the End-user/ Customer only if the product is covered by the aforementioned warranty. Armasight will return the product after warranty service by domestic UPS Ground service and/ or domestic mail. Should any other requested, required or international shipping methods be necessary, the postage/ shipping fee will be the responsibility of the End-user/ Customer.

1.4 LIST OF ABBREVIATIONS

C	Celsius (Centigrade)
CCW	counterclockwise
Cont'd	Continued
CW	clockwise
Dia	diameter
F	Fahrenheit
FOV	Field of View
g	gram
Gen	Generation
H	Height
hr	hour
IR	infrared
IT	Intensifier Tube
L	Length
LED	Light Emitting Diode
lx	lux
m	meter
mA	milliamperere
min	minute
mm	millimeter
mW	milliwatt
nm	nanometer
No	Number
NV	Night Vision
NVD	Night Vision Device
Para	Paragraph
PMCS	Preventive Maintenance Checks and Services
QRM	Quick Release Mount
QTY	Quantity
RMA#	Return Merchandise Authorization number
s	second
seq	sequence
SR	Service Representative
VDC	Volts Direct Current
V	Volt
W	Width

DESCRIPTION AND DATA

2.1 SYSTEM DESCRIPTION

The Nyx-7 is a hand-held, head-mounted or helmet-mounted night vision system that allows the user to operate it while walking, conducting short-range surveillance, reading maps, conducting vehicle maintenance, or administering first aid in both moonlight and starlight conditions.

The Nyx-7 utilizes the principle of intensification of the residual light that is reflected from the surrounding objects. The optical system of the unit consists of an objective lens, an intensifier tube (IT), and two eyepieces.

The Nyx-7 automatic brightness adjustment system retains the same gain (image brightness), even under unsteady light conditions.

A built-in IR illuminator makes it possible to use the unit in low light or total darkness.

The Nyx-7 uses LED lights to indicate illumination level, low battery, and to show the user that the IR illuminator is on.

The Nyx-7 allows for vertical and fore-and-aft adjustment when mounted to the user's head or helmet, when focusing the lens, and when focusing the eyepiece.

NOTE:

The equipment requires some light (moonlight, starlight, etc.) to operate. Performance of the device depends upon the level of ambient light in the environment. Please remember the following:

- The level of ambient light in the environment is reduced by the presence of clouds, shade, or objects that block natural light (trees, buildings, etc.).
- The equipment is less effective when operated in shadows and other darkened areas.
- The equipment is less effective when operated in rain, fog, sleet, snow, or smoke.
- Under starlight conditions, particularly in low-contrast environments such as snow-covered territory, sandy deserts, large bodies of water or grassy hills, the visibility may degrade, thereby disguising or masking changes in terrain.
- The equipment will not "see" through dense smoke.

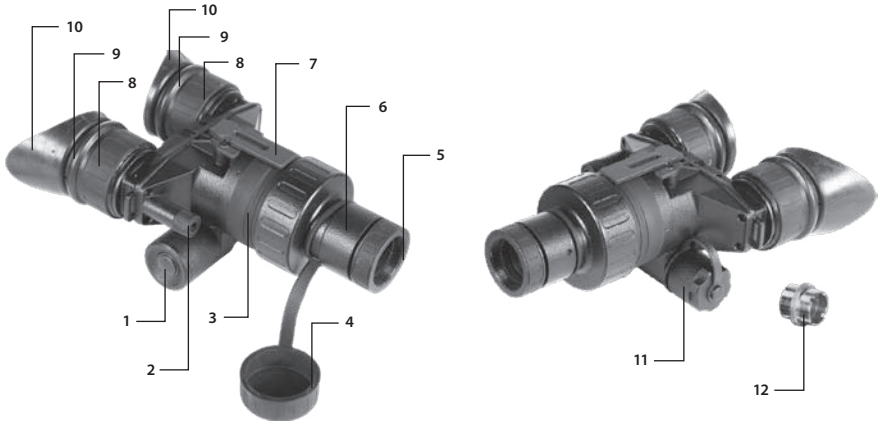

FIGURE 2-1. NYX-7 NIGHT VISION GOGGLES

TABLE 2-1. NYX-7 SYSTEM DESCRIPTION

ITEM	DESCRIPTION	ITEM	DESCRIPTION
1	Operating Button	7	Rail
2	IR Illuminator	8	Eyepiece Ring
3	Body	9	Eyepiece
4	Lens Cap	10	Eye-cup
5	Focus Ring	11	Battery Cap
6	Lens	12	Battery Adapter

2.2 SPECIFICATIONS

TABLE 2-2. MECHANICAL DATA

EQUIPMENT ITEM	DIMENSIONS, MM (L X W X H)/(DIA X L)	WEIGHT, G
Nyx-7 Night Vision Goggles	150x102x70	450
Goggle Kit	280x180x80	295
Flip-up Helmet Mount*	120x170x150	280
3X Afocal Lens*	Dia 77x95	550
5X Lens*	Dia 80x141	500
8X Lens*	Dia 96x211	730
IR810* / IR850*	117x41x37	102
IRN7 Adapter*	38x21x7.5	8

* *Optional.*

TABLE 2-3. ELECTRICAL DATA

ITEM	DATA
Battery*	One 123A (3V) or one AA (1.5V)
Consumption Current*:	38mA (123A) / 75 (AA)
Continuous Operation** at 20 °C:	
— 123A Battery	60 (IT Gen. 2+) / 50 (IT Gen. 3)
— AA Alkaline Battery	50 (IT Gen. 2+) / 40 (IT Gen. 3)

* Any AA or CR123 type rechargeable batteries with voltage from 1.2V to 3.7V can be used

** With IR illuminator off.

TABLE 2-4. OPTICAL DATA

ITEM	DATA
Magnification:	
— with 1X Lens	(1±0.5) X
— with 3X Afocal Lens*	(3±0.15) X
— with 5X Lens*	(5±0.2) X
— with 8X Lens*	(8±0.5) X
1X Lens:	
— Focal Length	24mm
— Lens F/number	1:1.2
Focus Range:	
— with 1X Lens	0.25m to infinity
— with 3X Afocal Lens*	5m to infinity
— with 5X Lens*	10m to infinity
— with 8X Lens*	15m to infinity
FOV:	
— with 1X Lens	40°
— with 3X Afocal Lens*	9°
— with 5X Lens*	9°30'
— with 8X Lens*	6°30'
Exit Pupil Diameter	14mm
Eye Relief	16mm
Eyepiece Diopter Adjustment	-5 to +5 diopters
Interpupillary Distance	58 - 72 mm
Built-in IR Illuminator	
— Power	50mW
— Illumination Range	20m
— Focus Distance	3m
— Illumination Wavelength	850nm

* *Optional.*

TABLE 2-5. ENVIRONMENTAL DATA

ITEM	DATA
Operating Temperature	-40 to +50 °C
Storage Temperature	-50 to +70 °C
Humidity	95%, 25°C to 40°C for 48 hr
Illumination Required	Natural night illumination (overcast starlight to moonlight)
Environmental Rating	Waterproof
MIL-STD-810	Complies

TABLE 2-6. IR850 SPECIFICATIONS

ITEM	DATA
IR Emitter Type	LED
Peak Wavelength	850 nm
Power	500 mW
Illumination Range	Up to 500 m
Divergence	8° to 12°
Battery	Single CR123A (3V)
Operational Time at 20 °C (68 °F)	From 1.5 hr (Full Power) to 10 hr (1/4 Power)
Overall Dimensions with Mount	117×41×37mm (4.6×1.6×1.7 in)
Weight (with Mount, without Battery)	102 g (3.6 oz)
Operating Temperature	-30 to +50°C (-22 to 122°F)
Storage Temperature	-50 to +70°C (-58 to 158°F)
Environmental Rating	Water Resistant

2.3 STANDARD COMPONENTS

Nyx-7 standard components are listed in Table 2-7 and shown in Figure 2-2.

**FIGURE 2-2. NYX-7 STANDARD COMPONENTS**

TABLE 2-7. NYX-7 STANDARD COMPONENTS

ITEM	DESCRIPTION	QUANTITY
1	Armasight Nyx-7 Night Vision Goggles Night vision goggles with unity magnification.	1
2	Objective Lens Cap A cap used to protect the lens and to be used when testing the unit in daylight.	1
3	Eyecup The rubber cups used to protect the eyepieces as well as provide comfort for the operator.	2
4	CR123A Lithium Battery A single, 123A lithium battery used to power the unit.	1
5	Goggle Kit Adjustable universal assembly that secures the Nyx-7 to the operator's head, providing hands-free operation.	1
6	Soft Carrying Case A protective case used for storing and carrying of the Nyx-7 and its accessories.	1
7	Operation and Maintenance Manual Provides safety information, equipment description, mounting procedures, operating instructions, and preventive maintenance checks and services (including a List of Spare Parts).	1

2.4 OPTIONAL EQUIPMENT

Nyx-7 optional equipment is listed in Table 2-8.

TABLE 2-8. NYX-7 OPTIONAL EQUIPMENT







IMAGE	DESCRIPTION	
	3X Afocal Lens Quickly converts the Nyx-7 into a long-range night vision device. Ideal for long range observation.	ANAF3X0002
	5X Lens Quickly converts the Nyx-7 into a long-range night vision device. Ideal for long range observation.	ANLE5X0003
	8X Lens Quickly converts the Nyx-7 into a long-range night vision device. Ideal for long range observation.	ANLE8X0005
	Helmet Mount Helps to mount the goggles to a range of ballistic helmets.	ANHM000001

TABLE 2-8. CONTINUED

	<p>IR850 Detachable Long Range Infrared Illuminator w/Dovetail to Weaver Transfer Piece #21</p> <p>An IR illuminator can provide an extra source of infrared light greatly enhancing the performance of night vision devices.</p>	ANKI000017
	<p>Neck Strap</p> <p>Neck strap helps to hold the Nyx-7 on your neck.</p>	ANAS000072
	<p>Hard Shipping/Storage Case</p> <p>A protective case used for the shipping/ storage of the Nyx-7 and its accessories.</p>	ANHC000001

2.5 KEY FEATURES

- High Quality Gen 2+/ 3 intensifier tube
- Super fast lens system provides the user with a clear, sharp image
- Dual eye viewing system for long viewing sessions
- Automatic bright light cut-off system to protect the intensifier tube
- LED lights visible in the eyepiece viewing area that indicate operation of the bright light cut-off system and IR illuminator, as well as to alert the user of a low battery
- Built-in IR illuminator
- Lightweight
- Compact and robust design
- Easy to operate
- Serviceability under severe conditions
- High-performance
- Highly reliable
- Powered by single CR123A or AA battery
- Head or helmet-mountable for hands-free usage
- Automatic ON/ OFF feature with flip-up head/ helmet mount
- Interchangeable lenses for different magnification
- Waterproof
- Limited two-year warranty

OPERATING INSTRUCTIONS

3.1 INSTALLATION AND MOUNTING

CAUTION:

To protect the intensifier tube when the sight is not in use or when it is being operated in daylight, keep the protective lens cap securely fitted over the lens.

3.1.1 BATTERY INSTALLATION

The Nyx-7 operates on a single CR123A or AA battery.

Depending on the size of the battery used, it may be necessary to reposition the battery adapter within the battery cap.

NOTE:

If operating the device at temperatures below -20°C (-4°F), the use of an alkaline battery is not recommended, as the severe cold will adversely affect the life of the battery. In these conditions, it is recommended that you use a lithium-iron disulfide 1.5V AA battery, or its equivalent.

Install the CR123A battery as follows:

1. Unscrew the battery cap (A) and insert the CR123A battery (B), observing the polarity markings on the body of the device.
2. With the battery adapter (C) installed, screw the battery cap (A) back on securely.

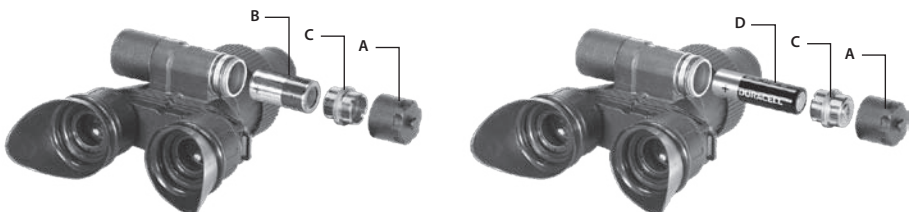

FIGURE 3-1. BATTERY INSTALLATION

3.1.2 MOUNTING THE NYX-7 TO A GOGGLE KIT

Mount the Nyx-7 to the optional goggle kit as follows:

1. Put on the goggle kit. Adjust the goggle kit strap pads until the goggles fit securely around your head. Remove the goggle kit.
2. Loosen the screw (A). While pushing down on the button (B), insert the Nyx-7 rail into the guide (C) of the goggle kit bracket. Tighten the screw (A).
3. Put on the goggle kit, now mounted with the Nyx-7.
4. To adjust the equipment for greater comfort, loosen the screw (A) and move the unit along the guide (C).
5. The goggle kit has a flip-up mechanism. Push the button (D) of the goggle kit bracket and lift the unit up until it reaches its topmost position.
6. Push the same button (D) to lower the unit into the correct viewing position.
7. Push the button (E) and move the unit along the slide-rail (F) until the most comfortable position is reached.
8. To remove the Nyx-7 from the goggle kit, loosen the screw (A), push the button (B), and slide the unit out of the bracket guide (C).

The Nyx-7 contains Flip-up Shutoff System. This system turns the unit off when the Nyx-7 is in the up-right position on the flip-up head mount. Turn the Nyx-7 on for continuation of the operation when the device is back into viewing position.



FIGURE 3-2. MOUNTING NYX-7 TO A GOGGLE KIT

3.1.3 MOUNTING THE NYX-7 TO A HELMET

An optional flip-up helmet mount can be used to attach the Nyx-7 to a helmet. The helmet mount fits the Nyx-7 securely onto the helmet via a rugged strapping device and grooved hooks. With the helmet mount, the Nyx-7 can be positioned directly in front of the user's eyes, or flipped backwards, out of the field of view.

Mount the Nyx-7 to a helmet as follows:

1. Attach the mount to the helmet as shown in Figure 3-3.
2. Adjust and tighten the straps (A).
3. Loosen the screw (B). With the button (C) pushed down, insert the Nyx-7 rail into the guide (D) of the helmet mount bracket. Tighten the screw (B).
4. Put on the helmet with the Nyx-7 attached.

5. Push the button (F) and move the unit along the slide-rail (G) until the most comfortable position is reached.
6. To adjust the unit for comfort, loosen the screw (B) and move the unit along the guide (D).
7. Turn the lever (I) and move the unit along vertical slide-rail until the most comfortable vertical position is reached.
8. To remove the Nyx-7 and turn it around, push the button (E) and lift the unit up until it reaches the topmost position.
9. Push the same button (E) to lower the Nyx-7 into the proper viewing position.
10. To remove the Nyx-7 from the helmet mount, loosen the screw (B), push down on the button (C), and slide the unit out of the guide (D).
11. To remove the flip-up mechanism from the helmet mount, loosen the lever (I), pull the knob out (H), and slide the flip-up mechanism out of the vertical rail.

The Nyx-7 contains Flip-up Shutoff System. This system turns the unit off when the Nyx-7 is in the upright position on the flip-up helmet mount. Turn the Nyx-7 on for continuation of the operation when the device is back into viewing position.

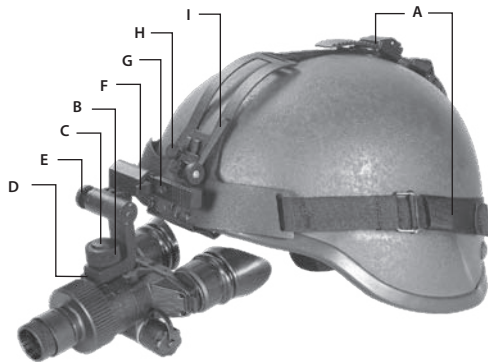

FIGURE 3-3. MOUNTING THE NYX-7 TO A HELMET

3.1.4 MOUNTING ACCESSORY LENSES TO THE NYX-7

To mount the 3X afocal lens to the device, screw it into the threading of the standard 1X objective lens on the Nyx-7.

To mount the 5X or 8X lens, unscrew the existing 1X objective lens of the Nyx-7 and screw in the 5X or 8X lens in its place.

The Nyx-7 configured with an 8X lens can be installed on a tripod. To mount the unit on a tripod, use the 1/4" threaded socket (E) on the housing of the 8X lens.



FIGURE 3-4. MOUNTING A 5X LENS TO THE NYX-7

NOTE:

The unit may be badly damaged if the tripod collapses or overturns. Remove the unit from the tripod if it is not within your reach.

3.1.5 MOUNTING AN IR ILLUMINATOR TO THE NYX-7

To mount an IR illuminator to the Nyx-7, use the transfer piece from IR illuminator kit. Perform the following steps:

1. Install the transfer piece (A) onto the Nyx-7 rail.
2. Tighten the fixing screw (B) on the transfer piece.
3. Loosen the IR illuminator fixing screw (C).
4. Mount the IR illuminator on the rail of adapter and tighten the fixing screw (C).

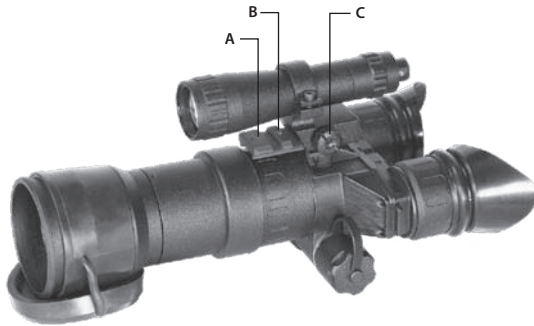

FIGURE 3-5. MOUNTING AN IR ILLUMINATOR TO THE NYX-7

3.2 CONTROLS AND INDICATORS

The Nyx-7 controls and indicators are defined in Table 3-1. The Nyx-7 controls are shown in Figure 3-6.

CAUTION:

DO NOT over-adjust the controls by forcing them past their stopping points.

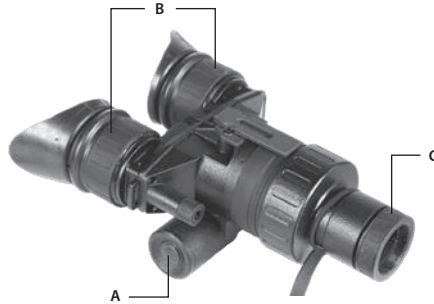

FIGURE 3-6. NYX-7 CONTROLS

TABLE 3-1. NYX-7 CONTROLS AND INDICATORS

CONTROL/INDICATOR	FUNCTION
Operating Button (Figure 3-14, A)	Controls unit power and built-in IR illuminator.
	To turn unit on and off push the button by short press (less than 1.5 sec). To turn the IR illuminator on and off push the button by long press (more than 1.5 sec).
Eyepiece Rings (Figure 3-14, B)	Adjusts the unit diopter. The total dioptic range is covered in a 1/2 ring revolution.
Focusing Ring (Figure 3-14, C)	Focuses the lens. Adjusts for sharpest view of the scene. The total focus range is covered in a 1/3 ring revolution.
Built-in LED Indicators	A PERMANENT RED GLOW in the eyepiece viewing area indicates that the IR illuminator is operating.
	A FLASHING RED LIGHT in the eyepiece viewing area indicates that the battery is low.

3.3 OPERATING PROCEDURES

3.3.1 OPERATING PROCEDURES

These procedures should be performed under nighttime conditions only.

CAUTION:

Use of the Nyx-7 brightly lit conditions may damage the unit's intensifier tube.

1. Verify that the battery is installed as indicated on the unit body.
2. Make a visual estimation of the illumination level in the viewing area. The required level of illumination is less than 1 lx (late twilight sky conditions).
3. Remove the lens cap.
4. Push the operating button by short press. After a slight delay, a green glow will appear in the eyepiece of the unit.
5. Adjust the unit diopter by rotating the ring of the eyepiece.
6. Observe the scene. Rotate the focus ring until the image is clear and sharp.

NOTE:

The front lens should be readjusted as you view objects at different distances.

CAUTION:

Bright light sources such as firelight, headlights, searchlights, etc. can damage the Nyx-7. Avoid exposing the unit to these types of light sources.

3.3.2 IR ILLUMINATOR OPERATIONS

CAUTION:

When operating the device in extremely dark conditions, the light from the unit's IR illuminator will be invisible to the unaided eye. However, the light can be detected by other NVDs.

NOTE:

The IR illuminator is designed to provide additional illumination (when needed) while viewing scenes or targets from a short distance (up to 3m).

1. To activate the IR illuminator, turn the unit on. Push the operating button by long press. A red light will appear in the eyepiece to indicate that the IR illuminator is operating.

3.3.3 NYX-7 SHUT-DOWN

1. To turn unit off push the operating button by short press. The green glow in the viewing area will fade to black.

2. Secure the lens cap over the objective lens.
3. If necessary, remove the unit from the rail. Remove the unit by following the mounting instructions in reverse.
4. Unscrew the battery cap and take out the battery. Replace the battery cap. Do not store the unit with the battery still in it.
5. Store the unit and all accessories in the case.

3.4 STORAGE

Prepare the Nyx-7 for storage as follows:

1. Verify that the Nyx-7 and all accessories are clean and dry before returning them to the storage case.
2. Secure the cap over the objective lens.
3. Remove the battery.
4. Place the Nyx-7 and accessories in the appropriate locations in the case, and close the cover.

PREVENTIVE MAINTENANCE AND TROUBLESHOOTING

4.1 PREVENTIVE MAINTENANCE CHECKS AND SERVICES (PMCS)

Table 4-1: Preventive Maintenance Checks and Services has been provided so that you can keep your equipment operable and in good condition.

Perform all functional tests in the order listed in Table 4-1.

Operating Procedures are detailed in Chapter 3.

A. Cautions

Always observe any CAUTIONS that appear in the table.

B. Explanation of Table Entries

SEQ NO. column. Sequence numbers are for reference and appear in the order required to perform checks and services.

LOCATION/ITEM TO CHECK/SERVICE column. Indicates the location and the item to be checked or serviced.

PROCEDURE column. Details the checking/ servicing procedure.

NOT FULLY MISSION CAPABLE IF... column. Indicates what faults will prevent your equipment from operating successfully.

TABLE 4-1. PREVENTIVE MAINTENANCE CHECKS AND SERVICES

SEQ NO.	LOCATION ITEM TO CHECK/SERVICE	PROCEDURE	NOT FULLY MISSION CAPABLE IF...
BEFORE OPERATION CHECKS			
1	Completeness	Open the carrying case and inventory all items by comparing them with the data specified in this manual.	Items are missing.
2	Soft Carrying Case	Shake out loose dirt or foreign material. Inspect for tears, cuts, excess wear or damage to the mounting clips.	
3	External Surfaces	Inspect for cracks or damage. Scratches and gouges are OK if operation is not affected.	Cracked or damaged.

TABLE 4-1. CONTINUED

SEQ NO.	LOCATION ITEM TO CHECK/SERVICE	PROCEDURE	NOT FULLY MISSION CAPABLE IF...
4	Lens Cap	Inspect for cracked, torn, or missing lens caps.	Cup is torn or cut. Cup is not secured to the housing of the lens.
5	Eyecups	Inspect for dirt or dust. Inspect for cracked, torn, bent, broken or improperly fitted eyecup. If necessary, clean as per Part 4.4.2.	Cup is torn or cut.
6	Battery Compartment/ Cap	Inspect for corrosion, moisture, corroded or defective contacts. Verify that the o-ring is present.	Contacts are damaged or corroded, or the o-ring is missing.
7	Lenses	Inspect optical surfaces for dirt, fingerprint residue, scratches, chips, or cracks.	Scratches or chips hinder vision when the Nyx-7 is turned on. Cracks are present.
8	Focusing Ring	Rotate the focusing ring to ensure free movement (range is approximately 1/3 turn).	Ring gets stuck or adversely affects the user's ability to properly focus the unit.
9	Eyepiece Rings	Rotate the eyepiece rings to make sure the eyepiece is not too tight or too loose. Range is approximately 1/2 turn.	Ring gets stuck, is too loose, or adversely affects the user's ability to properly adjust the diopter.
10	Goggle Kit	Check the straps and pads for cuts tears, fraying, holes, cracks or defective fasteners. Check the mount of goggle kit for dirt, dust or corrosion. Insert goggle rail into guide to verify secure attachment of goggle to head mount. If necessary, clean the mount with water. Press the buttons of the mount and check for free motion. Inspect for damage.	
11	Optional Equipment	Inspect optional items for dirt, or corrosion, damage, and missing parts. Check for proper operation. If necessary, clean as detailed in Part 4.4.2.	Equipment is damaged or parts are missing.

OPERATIONAL CHECKS

CAUTION:

Do not activate the Nyx-7 in daylight unless the lens cap is on, or you are operating under dark conditions.

NOTE:

Daylight checks are described below.

12	Operating Button	Install the battery. Push the button by short press. Look for the green glow in eyepieces (it should appear after a slight delay).	Image is present.
		Push the button by long press for activate the built-in IR illuminator. Look for a permanent red glow in the eyepiece viewing area.	Permanent red glow is absent
13	Viewed Image	Inspect for any operational defects (refer to Part 4.3: Identification of Operational Defects).	Shading, edge glow, flashing, flickering, and intermittent operation, or excessive cosmetic defects are found.

AFTER CHECKING PROCEDURES

14	<p>Turn the unit OFF. Verify that the green glow fades from the eyepieces.</p> <hr/> <p>Remove the battery.</p> <hr/> <p>Return the unit and all accessories to the soft carrying case.</p>
----	---

4.2 TROUBLESHOOTING

The purpose of troubleshooting is to identify the most frequently occurring equipment malfunctions, their probable causes, and the corrective actions required to fix them.

Table 4-2 lists common malfunctions that may occur during the operation or maintenance of the Nyx-7. Perform the tests, inspections, and corrective actions in the order listed in the table.

This table does not list all of the malfunctions that may occur with your device, or all of the tests and corrective actions that may be necessary. If you experience an equipment malfunction that is not listed, or is not fixed by the corrective actions listed in the table, please contact Armasight's Customer Service center.

TABLE 4-2. OPERATOR TROUBLESHOOTING

MALFUNCTION	PROBABLE CAUSE/TEST/INSPECTION	CORRECTIVE ACTION
Unit fails to activate.	Battery is dead, missing or improperly installed.	Replace the battery or install it correctly.
	Battery contact surfaces or contact springs are dirty or corroded.	Clean the contact surfaces with a pencil eraser and/ or alcohol and cotton swabs.
	Defective image intensifier.	Please contact Customer Support.
IR illuminator fails to activate.	Turn the IR illuminator on in a dark area. Visually estimate whether or not the observed scene is illuminated.	If the IR illuminator fails to activate, please contact Customer Support.
LED indicators fail to activate.	Visual inspection.	Please contact Customer Support.
Poor image quality.	Check objective lens or eyepiece focus.	Refocus the lens.
	Check for fogging or dirt on the lens.	Clean the lens as detailed in Part 4.4.2 of this manual. If image quality is still poor, please contact Customer Support.
	Damaged optical components.	Please contact Customer Support
Light is visible around the eyecup.	Check the exit pupil distance value.	Readjust for proper eye-relief distance.
	Check the eyecup resilience.	If the eyecup is defective, please contact Customer Support.
Focusing ring cannot be moved.	Check to see if the focusing ring is bent or broken.	If damaged, please contact Customer Support.
Eyepiece ring cannot be moved.	Check to see if the eyepiece ring is bent or broken.	If damaged, please contact Customer Support.

4.3 IDENTIFICATION OF OPERATIONAL DEFECTS

4.3.1 OPERATIONAL DEFECTS

Operational defects relate to the reliability of the intensifier, and are an indication of instability. If identified, the user will need to return the Nyx-7 immediately. Operational defects include shading, edge glow, flashing, flickering, and intermittent operation.

A. Shading

If shading is persistent, you will not be able to see a fully circular image (Figure 4-1). Shading is a very dark, high-contrast area with a distinct line of demarcation present, and you cannot see an image through it. Shading always begins on the edge, and will eventually migrate inward until it spans across the entire image area. If you notice shading with your device, please contact Customer Support.

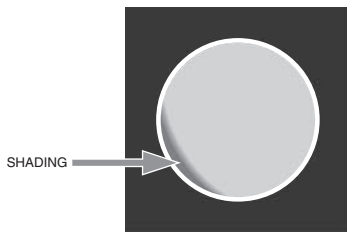

FIGURE 4-1. SHADING

NOTE:

Verify that any shading is not the result of improper eye-relief adjustment.

B. Edge Glow

Edge glow is a bright area (it sometimes appears to be sparkling) in the outer portion of the viewing area (see Figure 4-2). To check for edge glow, block out all light from the device by cupping a hand over the lens. If the image tube is displaying edge glow, the bright area will still show up; if edge glow occurs, please contact Customer Support.

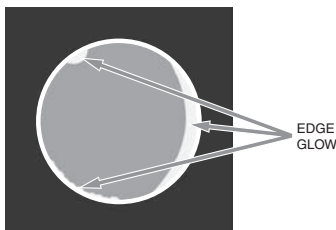

FIGURE 4-2. EDGE GLOW

C. Flashing, Flickering, or Intermittent Operation

The image may appear to flicker or flash. If there is more than a single flicker, check for a loose battery adapter or a weak battery. If flickering continues, please contact Customer Support.

4.3.2 COSMETIC BLEMISHES

Cosmetic blemishes are usually the result of manufacturing imperfections. They **do not** affect the reliability of the image intensifier, and are not normally a cause for returning the Nyx-7. However, some types of cosmetic blemishes can worsen over time and interfere with the user's ability to properly operate the device during missions. If you believe a cosmetic blemish is cause for returning the device, record the specific nature of the problem on the maintenance forms and use the clock method to identify the position of the blemish and its approximate distance from the center (e.g., 5:00 toward the outside, 2:30 near the center, or 1:00 midway).

The following are examples of cosmetic blemishes:

A. Bright Spots

A bright spot is a small, non-uniform bright area that may flicker or appear constant (Figure 4-3). Not all bright spots make the Nyx-7 rejectable. Cup your hand over the lens to block out all light. If the bright spot remains, please contact Customer Support. Bright spots usually go away when all light is blocked out. Verify that any bright spots are not simply the result of bright light in the area you are observing. Bright spots are acceptable if they do not interfere with the user's ability to view the scene or perform missions.

B. Emission points

Emission points are steady or fluctuating pinpoints of bright light in the image area that do not go away when all external light is blocked from the objective lens (Figure 4-3). The position of an emission point within the image area does not move. Not all emission points are cause to return the Nyx-7. Verify that emission points are not simply light sources present in the scene you are observing. Emission points are acceptable if they do not interfere with the user's ability to perform missions.

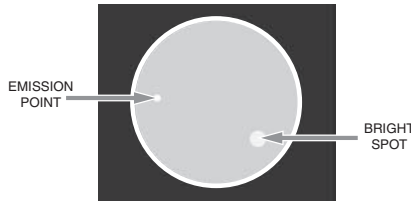

FIGURE 4-3. EMISSION POINTS AND BRIGHT SPOTS

C. Black Spots

Black spots are cosmetic blemishes in the image intensifier or debris between the lenses. Black spots are acceptable as long as they do not interfere with the user's ability to observe the scene. No action is required if this condition is present, unless the spots interfere with the operator's ability to perform missions.

D. Fixed-pattern Noise

Fixed-pattern noise is usually a cosmetic blemish characterized by a faint hexagonal (honeycomb) pattern that appears throughout the viewing area. This typically occurs in excessively lit environments or when viewing very bright lights (See Figure 4-4). This pattern can be seen in every image intensifier if the level of light is high enough. This condition is acceptable as long as the pattern does not interfere with the user's ability to view an image or interfere with their ability to perform missions.

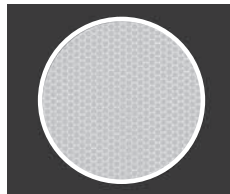

FIGURE 4-4. FIXED-PATTERN NOISE

E. Chicken Wire

Chicken wire is an irregular pattern of dark thin lines that can appear in the field of view, either throughout the image area or in sections of the image area (See Figure 4-5). In the worst-case scenario, these lines will form hexagonal or square, wave-shaped lines. No action is required if this condition is present, unless it interferes with the user's ability to view the image or their ability to perform missions.



FIGURE 4-5. CHICKEN WIRE

4.4 MAINTENANCE

4.4.1 GENERAL

The section regarding Nyx-7 operator maintenance consists of operational tests, inspections for unit serviceability, cleaning and mounting procedures, troubleshooting, and replacement instructions for a limited number of parts. Maintenance instructions covered elsewhere in this manual (PMCS, troubleshooting, etc.) are not repeated in this section.

CAUTION:

The Nyx-7 is a precision electron-optical instrument, and must be handled carefully at all times to prevent damage to the device's body or mechanisms.

4.4.2 CLEANING PROCEDURES

CAUTION:

Thoroughly dry each item before placing them into the storage case.

Clean the Nyx-7 as follows:

1. Gently brush off any dirt from the unit's body using a clean, soft cloth.
2. Moisten the cloth with fresh water and gently wipe down external surfaces (**except** for glass surfaces).
3. Dry any wet surfaces (**except** for glass surfaces) with another clean, soft, dry cloth.
4. Using a lens brush, carefully remove all loose dirt from the glass surfaces.
5. Slightly dampen a cotton swab with ethanol. Gently and slowly wipe the lenses. Without touching the lens holders, clean the glass surfaces in circular movements, beginning in the center and moving out towards the edge. Change the cotton swab after each circular stroke. Repeat until the glass surfaces are clean.
6. Clean the battery contact surfaces and contact springs with a pencil eraser and/ or alcohol-dampened cotton swabs.

Clean optional mounting devices with a soft brush (cloth), soap, and water as required.

Clean optional lenses as detailed in items 4 and 5 above (**except** for the demist shield).

4.4.3 BATTERY REMOVAL AND REPLACEMENT

Refer to Part 3.1.1 for battery installation procedures. No special tools are required to replace the battery.

4.4.4 GOGGLE KIT MAINTENANCE

A. Browpad Replacement

Replace the browpad when cracked, torn, or contaminated. Perform the following to remove and replace the browpads:

1. Firmly grasp the goggle kit and remove the old browpad.
2. Gently press on the new browpad. Gently smooth out any wrinkles in the new browpad.



FIGURE 4-6. BROWPAD REPLACEMENT

B. Chin Strap Reinstallation

1. Detach the Velcro tape from the left side of the headband and remove the chin strap. Unfasten the chin strap from the strap assembly.
2. Replace the chin strap by joining the sides of the Velcro tape on the left side of the headband and threading the end of another strap into the corresponding buckle on the right side of the headband.

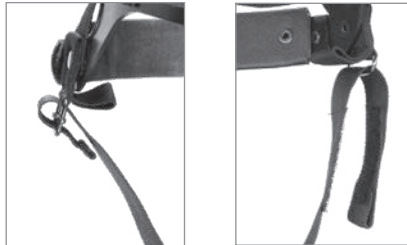

FIGURE 4-7. CHIN STRAP REINSTALLATION

C. Chin Cup Replacement

1. Detach the Velcro tape from the left side of the head-band and remove the chin strap.
2. Slide the chin cup out from the chin strap and replace it with a new one. After replacing the chin cup, attach the Velcro on the left side of the head-band.



FIGURE 4-8. CHIN CUP REPLACEMENT

4.5 SERVICE/PACKING AND UNPACKING

For service, repair or replacements, please email: service@armasight.com.

To assist the Service Representative (SR) with determining if the item is repairable, please provide the following information:

1. Serial Number of the defective item.
2. Thorough description of the malfunction, defect or damage.
3. An explanation of how the malfunction, defect or damage occurred, if known.

If the SR determines that the item is under warranty or should be returned for repair, a Return Material Authorization number (RMA#) will be provided. RMA can be obtained via e-mail to service@armasight.com or via phone by calling Armasight Customer Service at (888)959-2259 Ext. 2 or via fax (888)959-2260.

When returning the Nyx-7 for service or repair, the following procedures should be followed to prevent any additional damage:

1. Verify that the Nyx-7 is free of all contaminants such as dirt or any other foreign material.
2. Remove the battery.
3. Place the cap over the lens.
4. Place the Nyx-7 in the hard shipping/ storage case or soft carrying case (if available). If the hard shipping/ storage case is not available, individually package each Nyx-7 unit being returned in a suitable container.

Place the Nyx-7 and a copy of the test report or detailed description of the failure in a suitable packing/ shipping container. Mark the package with the RMA#. Ship the items using the fastest, most easily traceable, prepaid method to:

Armasight Inc.
815 Dubuque Avenue
South San Francisco, CA 94080
USA.

A. NYX-7 LIST OF SPARE PARTS

The parts authorized in this list of spare parts are required for operator maintenance. This list includes parts that must be removed in order to replace authorized parts.

The ITEM NO. Column indicates the number used to identify items in Figure A-1.

The PART NO. Column indicates the primary number used by the manufacturer to identify an item; this number controls the design and characteristics of the item by means of its engineering, specifications, standards, and inspection requirements.

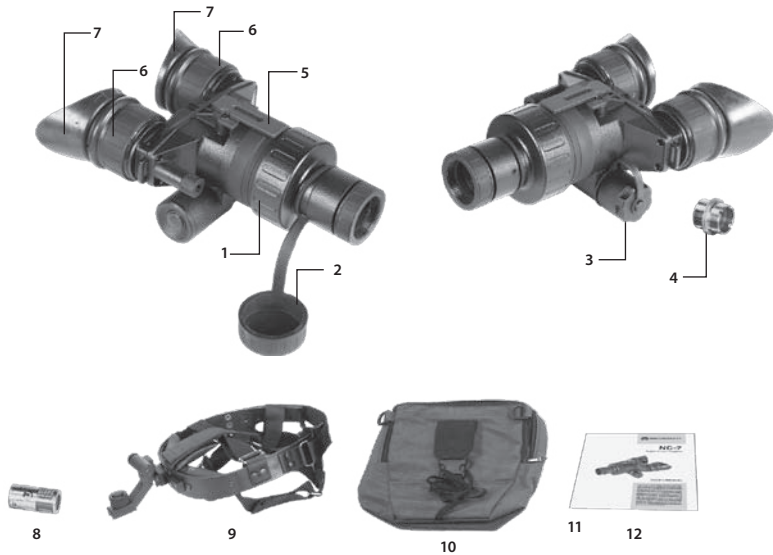

FIGURE A-1. NYX-7 SPARE PARTS

TABLE A-1. NYX-7 LIST OF SPARE PARTS

ITEM NO.	DESCRIPTION	PART NO.
1	Objective Lens Assembly	NG7OLA
2	Lens Cap	NG7LC
3	Battery Cap	NG7BC
4	Battery Adapter	NG7BA
5	Rail	NG7RL
6	Eye-piece Assembly	NG7EPA
7	Eye-cup Assembly	NG7ECA
8	CR123A Lithium Battery	CR123A
9	Goggle Kit	NG7GK
10	Soft Carry Case	NG7SCC
12	Operation and Maintenance Manual	NG7OMM

B. PRODUCT WARRANTY REGISTRATION CARD

In order to validate the warranty on your product, Armasight must receive a completed Product Warranty Registration Card for each unit, or the Customer must complete warranty registration on our website at www.armsight.com. Please complete the included form and immediately mail it to our Service Center:

Armasight Inc.
 815 Dubuque Avenue
 South San Francisco, CA 94080
 USA

ARMASIGHT PRODUCT WARRANTY REGISTRATION CARD

PRODUCT INFORMATION

Product Name _____ Purchased From _____

Purchase Date _____ Product Serial # _____

CUSTOMER INFORMATION

Name _____

Address _____

City _____ Country _____ Zip _____

Day Phone # _____ Home Phone # _____

E-mail address _____

.....
 Customer Signature Required

ALPHABETICAL INDEX

A

Abbreviations 10

B

Battery Installation 19

Black Spots 35

Bright Spots 35

C

Cautions 2

Chicken Wire 36

Cleaning 36

Continuous Operation 13

Cosmetic Blemishes 34

D

Diopter Adjustment 13, 28

E

Edge Glow 34

Emission Points 35

Eye Relief 13, 20

F

Fixed-Pattern Noise 35

Flashing, Flickering, or Intermittent Operation 34

G

General Information 7

H

Height 22

I

IR Illumination Range 14

IR Illuminator 2, 12, 29

L

Length 13

M

Magnification 13

Maintenance 31, 36

- Goggle Kit 36

- Preventive 31

Mounting 18

O

Objective Lens Focus 27, 28

Operating button 12, 27

Operating Instructions 17

Operational Defects 34

Operator Troubleshooting 33

P

PMCS 31

Preparations for Storage 31

S

Safety Summary 2

Shading 34

Spare Parts 39

System Description 11

W

Warranty Information 8

Weight 12

Width 12



Armasight Inc.

815 Dubuque Avenue
South San Francisco
CA 94080, USA

Phone: (888)959-2259

Fax: (888)959-2260

Intl Phone/Fax: (650)492-7755

info@armasight.com

CAUTION:

This product contains natural rubber latex which may cause allergic reactions! The FDA has noted an increase in the number of reported deaths that are associated with an apparent sensitivity to natural latex proteins. If you are allergic to latex, it is a good idea to learn which products contain it and strictly avoid exposure to those products.

www.armasight.com